

T40S

(New LED compatible model)

www.greenbrook.co.uk



Important

This unit should be installed to the current IET Wiring Regulations.

A qualified electrician is required for installation.

Turn off electrical supply from the Main Switch Fuseboard / Consumer unit.

Note:

This timer requires a 2A BS646 fuse .
Two fuses are supplied with the timer, one in the fuse carrier and one as a spare.

Wiring Installation in One-Way Switched Circuit

Installation if using on a standard one-way switched circuit, follow Diagram 1.

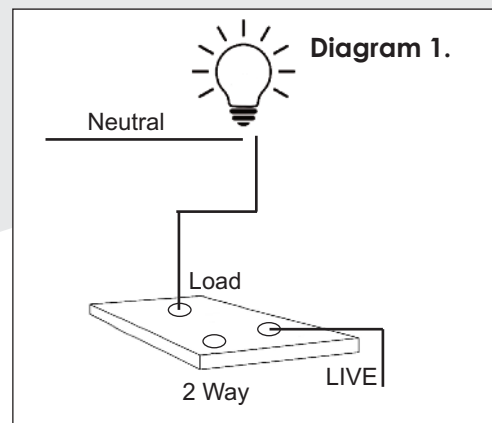

YELLOW & GREEN EARTHS MUST REMAIN CONNECTED TO METAL BACK BOX

Wiring Installation in Two-Way Switched Circuit

Installation if using on a two-way circuit with three wires at each switch, follow Diagram 2.

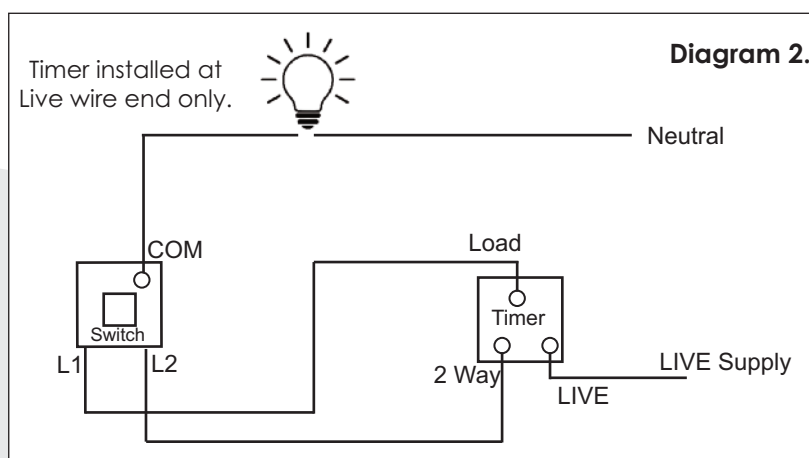

YELLOW & GREEN EARTHS MUST REMAIN CONNECTED TO METAL BOX

Please see overleaf for wiring installation in Two-Way Switched Circuit with a 3 & 5 way wire arrangement.

Wiring Installation in Two-Way Switched Circuit with a 3 & 5 Way Wire Arrangement

Installation if using on a two-way switched circuit with a 3 & 5 Way wire arrangement, follow Diagram 3 & 4.

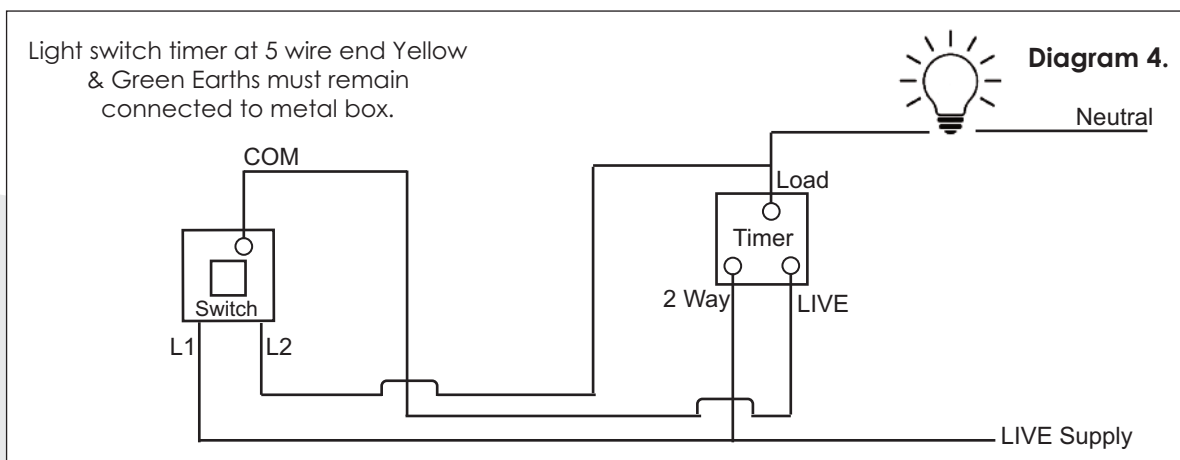
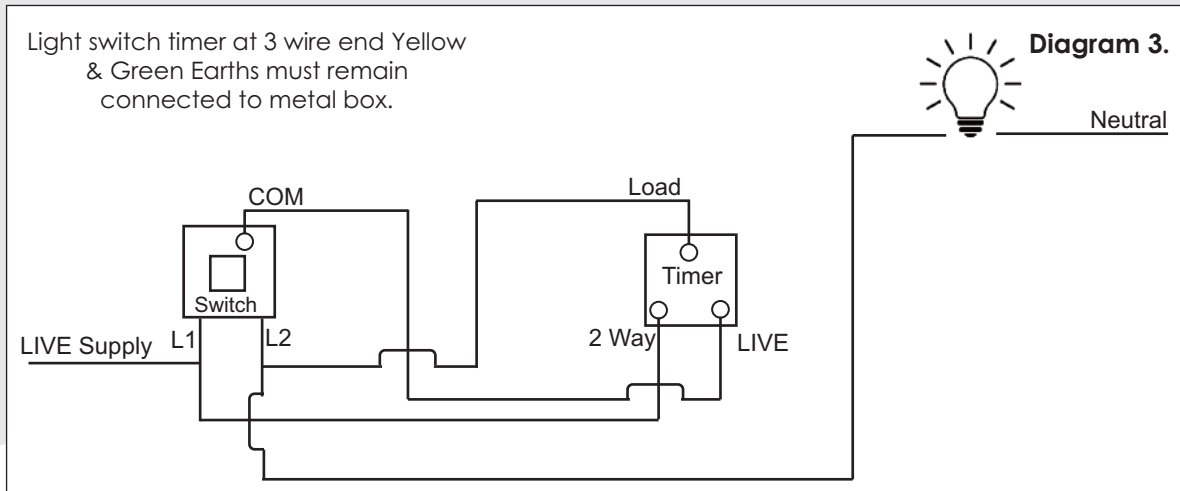

Timer Set Up Information

When wiring is connected ensure all lamps in the circuit are in good working order and all switches are ON, Power up and leave for 60 minutes to charge battery.

A display of dashes should be on the LCD screen, then follow programming instructions as supplied with the timer.

Please note for 'Over Night' settings i.e. on at 8pm off for 2am for all days of the week set as below.

- Set correct time and day.
- Set programme one ON for 20 00 with all days of week showing.
- Set programme one OFF for 23 59 with all days of week showing.
- Set programme two ON for 00 01 with all days of week showing
- Set programme two OFF for 02 00 with all days of week showing.

Note:

When the timer is following the set programme times ensure override switch is showing AUTO.

If there is no display on the display screen, ensure all lamps in circuit are good and the timers fuse holder is pushed in fully.

If you are experiencing issues with the lamps flickering, please replace for another model.

Please Note:

If you are replacing the **original T40S-C** timer with the new model on a two-way wiring circuit. that has a 3 & 5 wire arrangement please note a wiring modification is required as shown on Diagrams 3 & 4 above.