

Installation Instructions for Cylinder Thermostat - TH90CS

Cylinder thermostat with volt free switch contacts complete with cable clamp. This model is suitable for measuring temperatures on hot water cylinders. Thermostat clamping is achieved by means of a spring-band, assuring good contact and fixing to tanks.

Important: This product should be installed by a competent person and in accordance with the current IET Wiring Regulations. If in doubt consult a qualified electrician.

TERMINAL CONNECTION

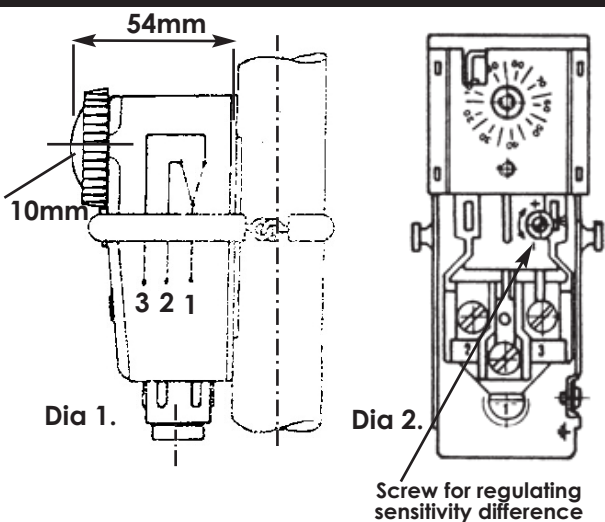

Terminal Connection:

- Terminal 1.** - Common inlet
- Terminal 2.** - Outlet (opens the circuit with increasing temperature)
- Terminal 3.** - Outlet (closes the circuit with increasing temperature)



TECHNICAL INFORMATION

Temperature Range:	10°/90°C
Temperature Differential:	Dt 5° + 10°C
Contacts:	Ag
Contacts Rating:	15A (2.5) 230V
Number of Automatic Cycles:	II (100,000)
Temperature Rate of Change:	1°C/min
Degree of Protection:	IP20

GUARANTEE

Your GreenBrook Cylinder Thermostat TH90CS is guaranteed for 1 year from the date of purchase. This is in addition to your statutory rights.

Note: When disposing of this item and its packaging please follow local regulations and use an appropriate waste disposal centre. Please see the GreenBrook website for further details.

PLEASE KEEP THESE INSTRUCTIONS
SAFE FOR FUTURE REFERENCE